



Company Information

Company Name	<i>Stainless Valve Company</i>	Date Submitted	<i>4/20/2021</i>
Project Title	<i>Design of a Pollution-free Pneumatic Actuation System (SVC_SYSTEM)</i>	Planned Starting Semester	<i>Fall 2022</i>

Senior Design Project Description

Personnel

Typical teams will have 4-6 students, with engineering disciplines assigned based on the anticipated Scope of the Project.

Please provide your estimate of staffing in the below table. The Senior Design Committee will adjust as appropriate based on scope and discipline skills.

Discipline	Number	Discipline	Number
Mechanical	5	Electrical	
Computer		Systems	

For over 30 years Stainless Valve Company has supplied through-port valves of simple design yet made to very stringent design requirements resulting in very reliable, high performance valves. Our valves have proven impressive performance in some of industry’s most difficult and demanding applications. The flagship valve is the Stargate-O-Port-Valve®. See images below:





**INDUSTRIAL SOLUTIONS
LABORATORY**

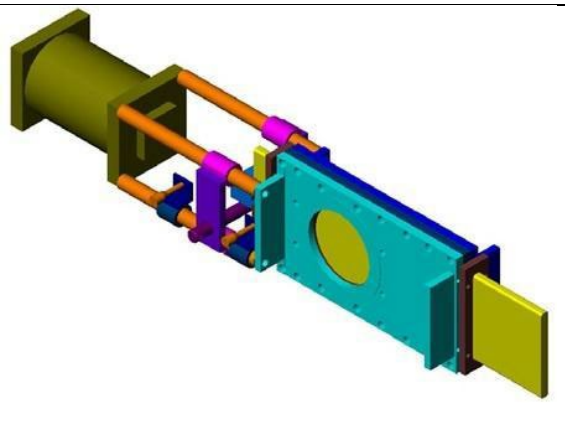
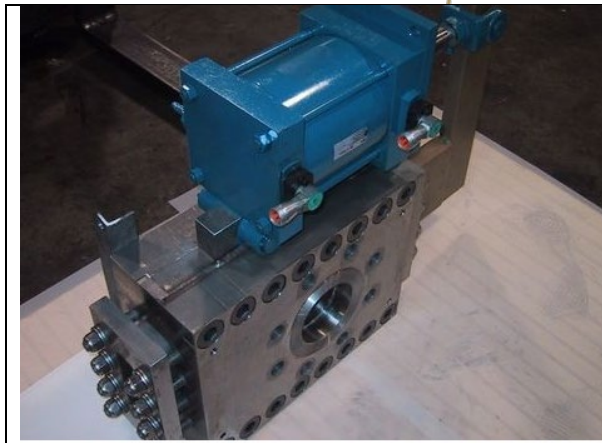

In the Pulp and Paper industry Stargate-O-Port-Valves are used as isolation valves for process gas, mixing pumps, bleaching towers, batch digesters, continuous digesters, blow tanks, washers, stock pumps, liquor heaters, liquor supply lines, lime storage bins, recovery boiler, green liquor, pulp storage tanks, manifolds for high consistency stock, fly ash bins, filling valves on reactors, catalyst recycling reactors etc. This project will seek to develop a proof of concept of a variant design for a new application in gas transport.



This project is partially supported by a grant from the NC Manufacturing Extension partnership, an organization that helps to support business and job growth for NC companies. To learn more about the NC MEP, click on this link: <https://www.ncmep.org/>.

Project Requirements:

In the hydrocarbon industry especially in that portion, which is concerned with the transport of natural gas, propane, butane, methane, ethane, pentane, hexane, coke gas and others through pipelines over long distances, the control of the gas flow is most important for the efficient transport of the gas.

When gas flows through a pipe initially the flow speed is identical over the cross section of the pipe. With increasing distance from the start of the pipeline the flow speed towards the center of the pipe increases relative to the speed along the periphery. The reason is the friction between the



gas and the pipe wall, which slows the gas flow down. The result is a parabolic relation, between the flow speed and the pipe diameter.

Eventually the speed difference between center and periphery approaches the speed of sound. At that point the system becomes unstable and no efficient gas transport can be carried out.

Before reaching this point the gas flow has to be directed to a pumping station, which increases the gas pressure back to the original pressure, this way eliminating the losses from the gas friction with the pipe.

Along a pipe line there are many locations where valves are installed to direct the gas to the pumping stations, splitting the flow to another consumer area, feeding alternate pipes so that others can be maintained, shutting off the flow completely etc. Very often these valves are located in areas where there is no electricity available. In such a situation the pressure of the gas in the pipeline is used to be diverted to actuators, which close or open the pipe line valves. This is an elegant solution, when there is no other energy available. However, there are two drawbacks to this approach:

1. The gas, which is used for actuation, is lost from the flow in the pipeline, i.e. a monetary loss.
2. The gas from the exhaust of the actuator is blown into the environment, which contributes to greenhouse gas emissions.

The objective of this project is to design an “exhaust eliminator” modification to the Stargate-O-Port valve to find a way to use the gas from the pipeline for the actuation but feed the exhaust gas back into the pipeline. Both the monetary loss and the negative influence on the environment are eliminated that way.

Expected Deliverables/Results:

- Survey current state-of-the-art and patented designs (in course time available) to develop alternative design concepts and avoid infringing on any other designs.
- Drawing the design of the exhaust eliminator mechanical addition using an example of an existing drawing of a Stargate-O-Port-Valve as a baseline.
- Calculate the mass-balance.
- Manufacture a proof-of-concept for the exhaust eliminator for use on an existing Stargate-O-Port-Valve®.
- Testing and adjusting the System for proper functionality.

Disposition of Deliverables at the End of the Project:

Students are graded based on their display and presentation of their team’s work product. It is mandatory that they exhibit at the Expo, so if the work product was tested at the supporter’s



location, it must be returned to campus for the Expo. After the expo, the team and supporter should arrange the handover of the work product to the industry supporter. This handover must be concluded within 7 days of the Expo.

List here any specific skills, requirements, specific courses, knowledge needed or suggested (If none please state none):

- Use of Access and Excel
- Knowledge of gas dynamics
- Design capability using SolidWorks.
- General job-shop capabilities to build and assemble the exhaust eliminator proof of concept
- Testing of the exhaust eliminator.
- Travel to Industry Supporters site as required.